



Motion-Plane-Adaptive Inter Prediction in 360-Degree Video Coding

Andy Regensky

andy.regensky@fau.de

Chair of Multimedia Communications
and Signal Processing



Friedrich-Alexander-Universität
Technische Fakultät



Motivation



Motivation

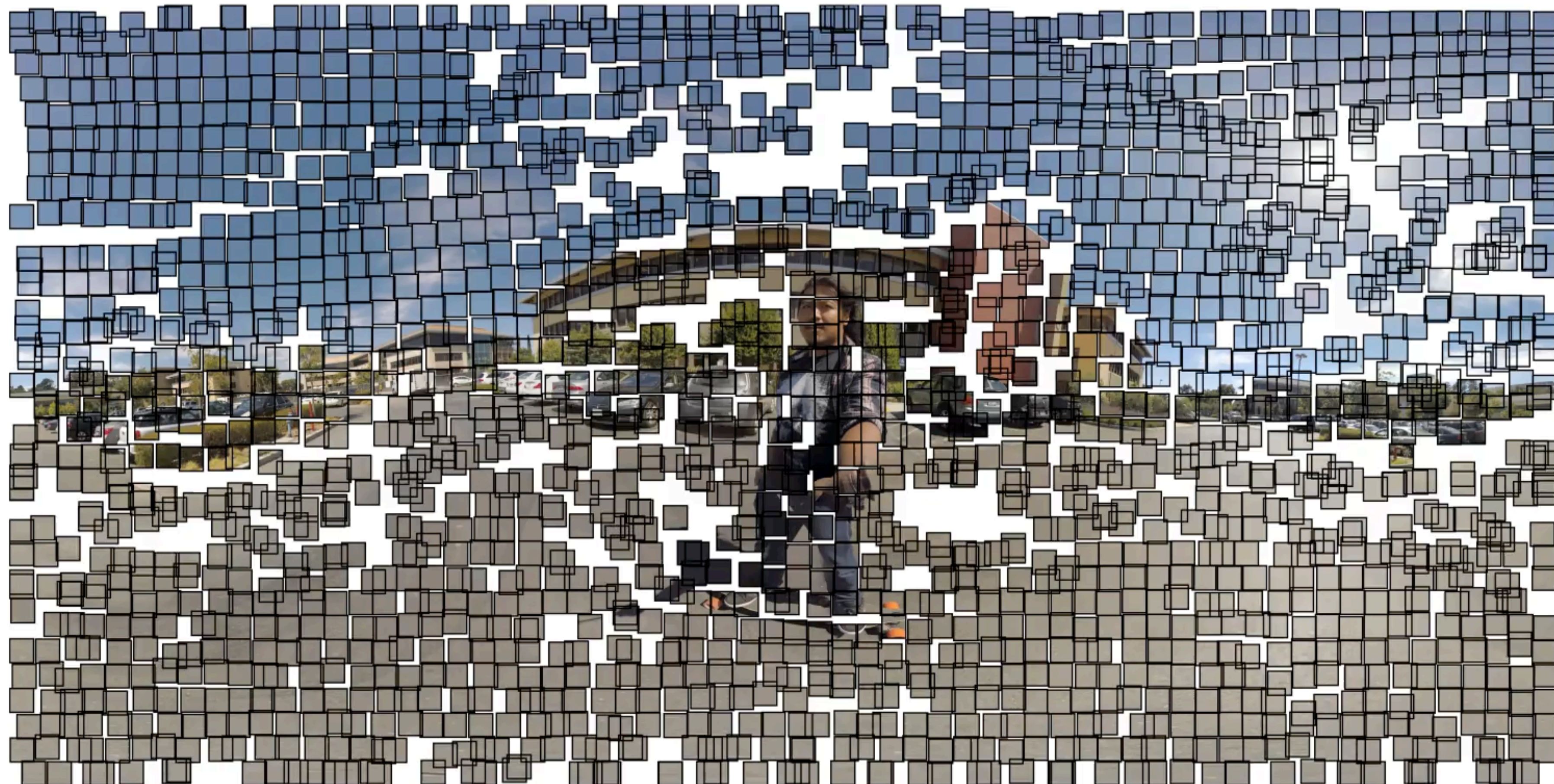

Motivation

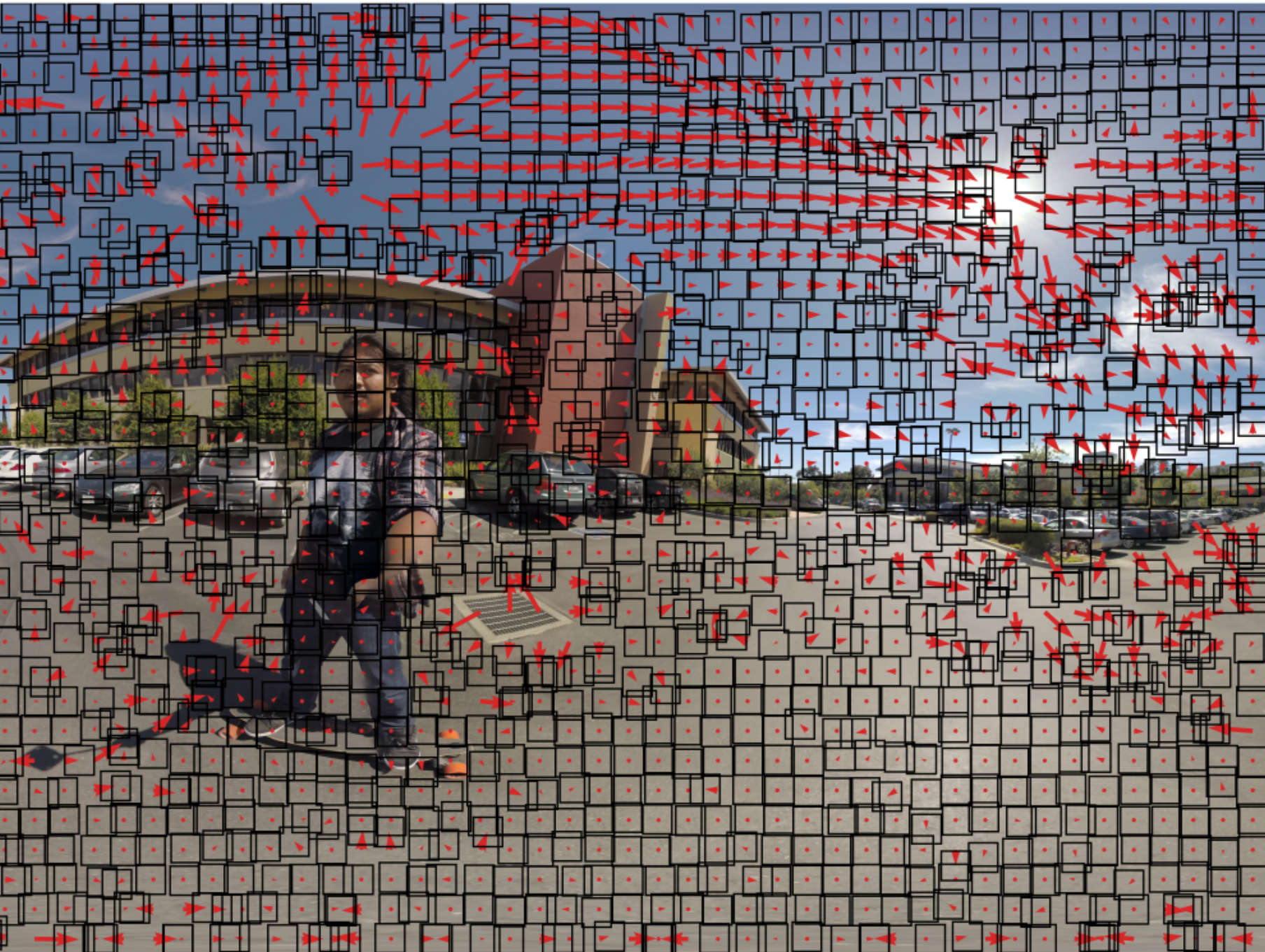

$$\mathbf{I}_{\text{pred}}(\mathbf{p}) = \mathbf{I}_{\text{ref}}(\mathbf{m}_t(\mathbf{p}, \mathbf{t}_{ij}^*)) \quad \forall \mathbf{p} \in \mathcal{B}_{ij}$$

- $\mathbf{I}_{\text{pred}} \in \mathbb{R}^{U \times V}$: predicted image
- $\mathbf{I}_{\text{ref}} \in \mathbb{R}^{U \times V}$: reference image
- $\mathbf{p} \in \mathbb{R}^2$: pixel coordinate
- $\mathbf{t}_{ij}^* \in \mathbb{R}^2$: motion vector for block (i, j)
- \mathcal{B}_{ij} : set of pixel coordinates within block (i, j)
- $\mathbf{m}_t : \mathbb{R}^2 \times \mathbb{R}^2 \rightarrow \mathbb{R}^2$: translational motion model with $\mathbf{m}_t(\mathbf{p}, \mathbf{t}) = \mathbf{p} + \mathbf{t}$

Motivation

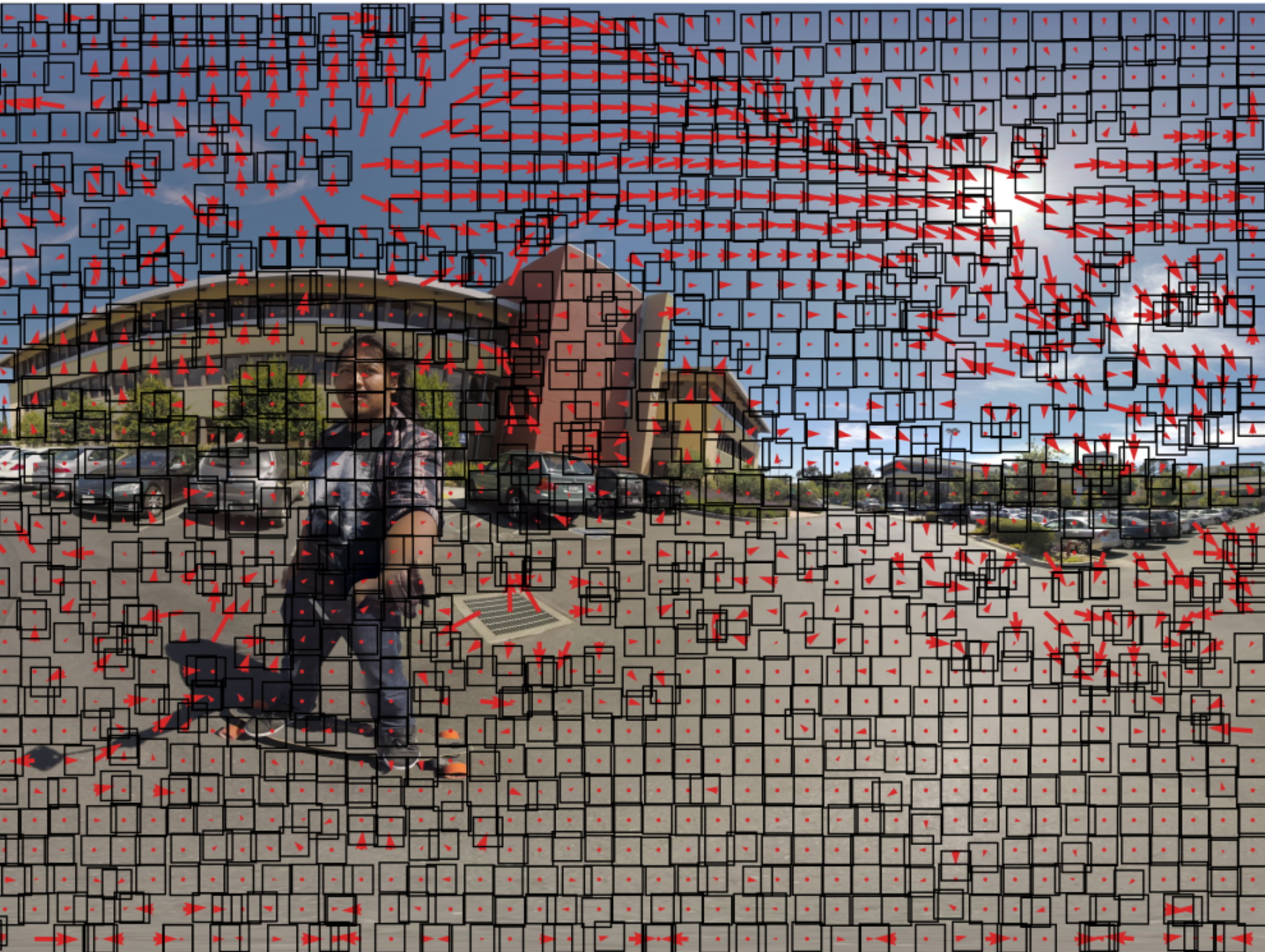

$$I_{\text{pred}}(\mathbf{p}) = I_{\text{ref}}(m_t(\mathbf{p}, t_{ij}^*)) \quad \forall \mathbf{p} \in \mathcal{B}_{ij}$$

- 3D-Translational: *Li et al., Wang et al.*
- Tangential: *De Simone et al.*
- Rotational: *Vishwanath et al.*
- Geodesic: *Vishwanath et al.*
- Tangential + Rotational: *Marie et al.*

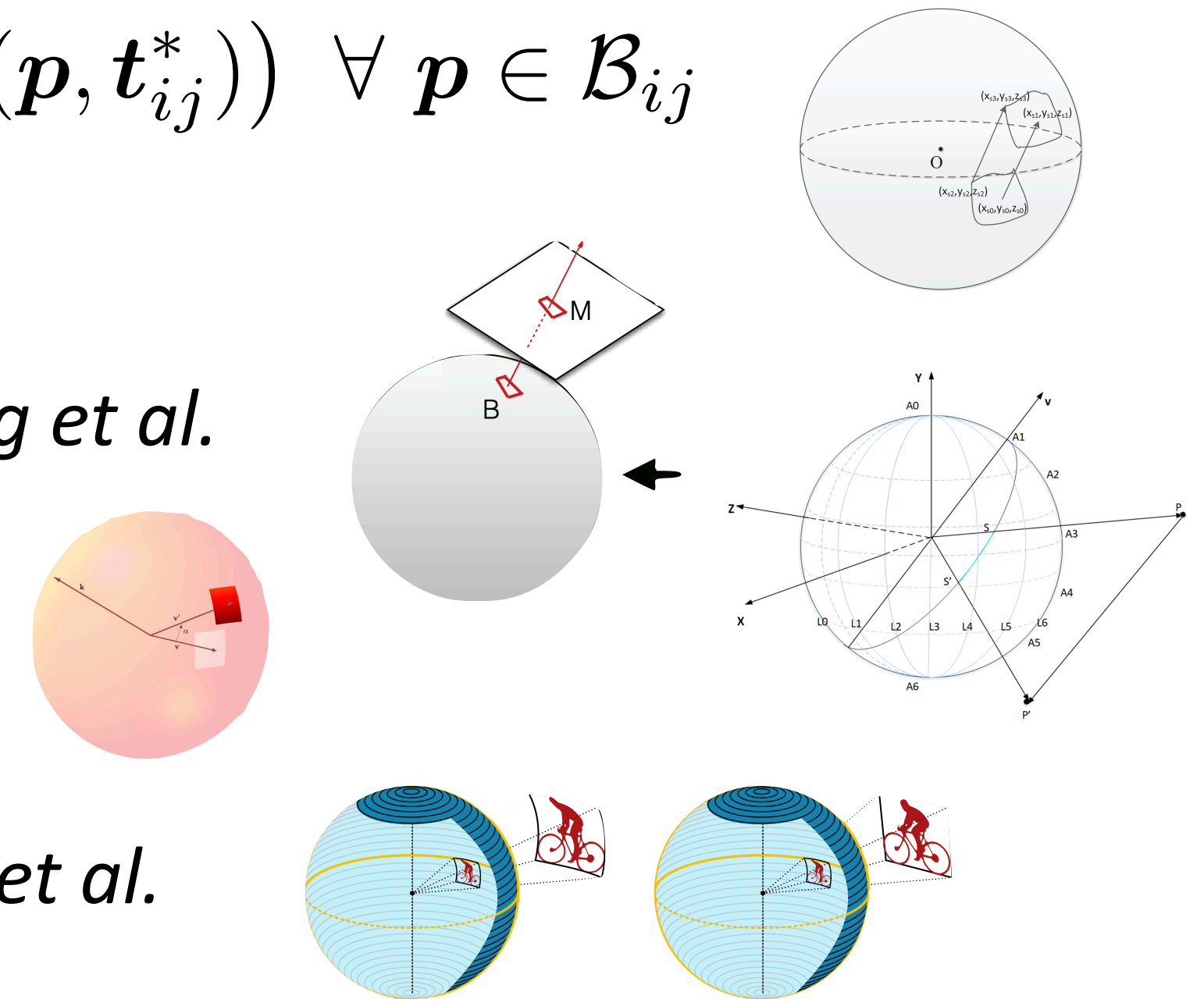

Li et al., "Projection Based Advanced Motion Model for Cubic Mapping for 360-Degree Video," in Proc. IEEE International Conference on Image Processing (ICIP), 2017, pp. 1427–1431.

Li et al., "Advanced Spherical Motion Model and Local Padding for 360° Video Compression," IEEE Trans. Image Process., vol. 28, no. 5, pp. 2342–2356, May 2019.

Wang et al., "A New Motion Model for Panoramic Video Coding," in Proc. IEEE International Conference on Image Processing (ICIP), 2017, pp. 1407–1411.

Wang et al., "Spherical Coordinates Transform-Based Motion Model for Panoramic Video Coding," IEEE J. Emerg. Sel. Top. Circuits Syst., vol. 9, no. 1, pp. 98–109, Mar. 2019.

De Simone et al., "Deformable Block-Based Motion Estimation in Omnidirectional Image Sequences," in Proc. IEEE 19th International Workshop on Multimedia Signal Processing (MMSP), 2017, pp. 1–6.

Vishwanath et al., "Rotational Motion Model for Temporal Prediction in 360 Video Coding," in Proc. IEEE 19th International Workshop on Multimedia Signal Processing (MMSP), 2017, pp. 1–6.

Vishwanath et al., "Rotational Motion Compensated Prediction in HEVC Based Omnidirectional Video Coding," in Proc. Picture Coding Symposium (PCS), 2018, pp. 323–327.

Vishwanath et al., "Motion Compensated Prediction for Translational Camera Motion in Spherical Video Coding," in Proc. IEEE 20th International Workshop on Multimedia Signal Processing (MMSP), 2018, pp. 1–4.

Marie et al., "Rate-Distortion Optimized Motion Estimation for on-the-Sphere Compression of 360 Videos," in Proc. IEEE International Conference on Acoustics, Speech and Signal Processing (ICASSP), 2021, pp. 1570–1574.

Outline

1. **Motion-Plane-Adaptive** Inter Prediction
 - a. Motion-Plane-Adaptive **Motion Model** (MPA)
 - b. Adapted **Motion Vector Prediction** (MPA-MVP)
2. Performance Evaluation
3. Conclusion

Motion Planes

- Virtual **perspective** camera
- Set of **three** motion planes
- Left/Right
- Front/Back
- Bottom/Top
- **Each CU** selects motion plane leading to **minimum RD-cost**

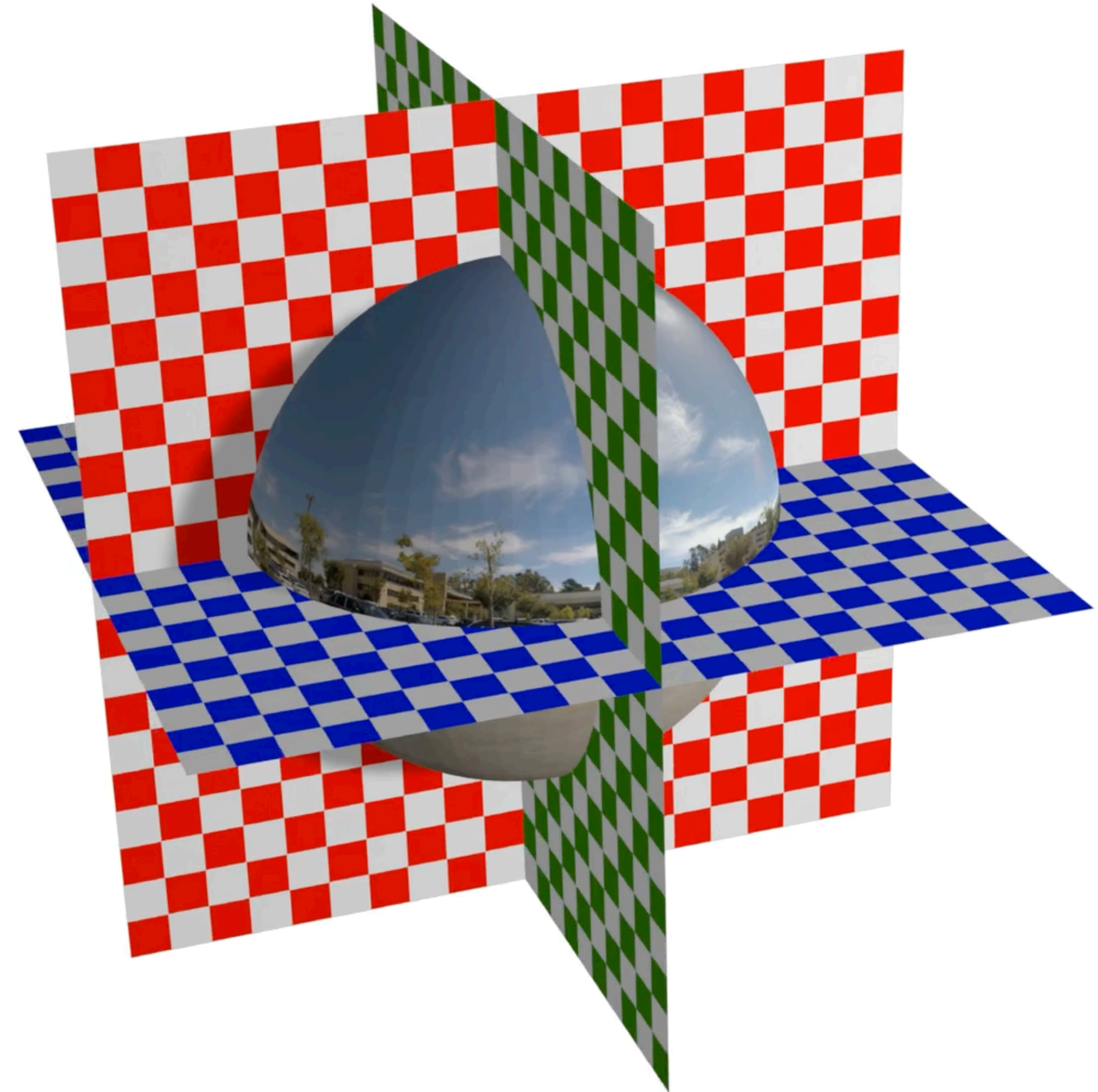

Motion-Plane-Adaptive Motion Model

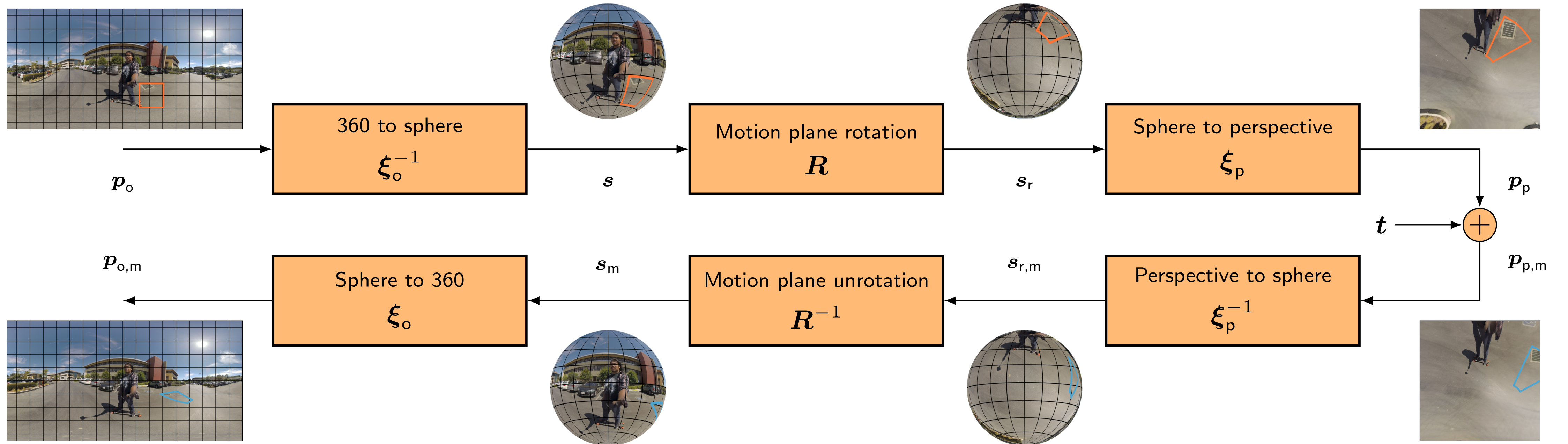

Motion plane reprojection

$$\zeta_R(p_o) = \xi_p(R\xi_o^{-1}(p_o))$$

Motion-plane-adaptive motion model

$$m_{mpa}(p_o, t, R) = \zeta_R^{-1}(\zeta_R(p_o) + t)$$

Regensky et al., "Motion-Plane-Adaptive Inter Prediction in 360-Degree Video Coding," arXiv:2022.03323, Feb. 2022.

Motion-Plane-Adaptive Motion Vector Prediction

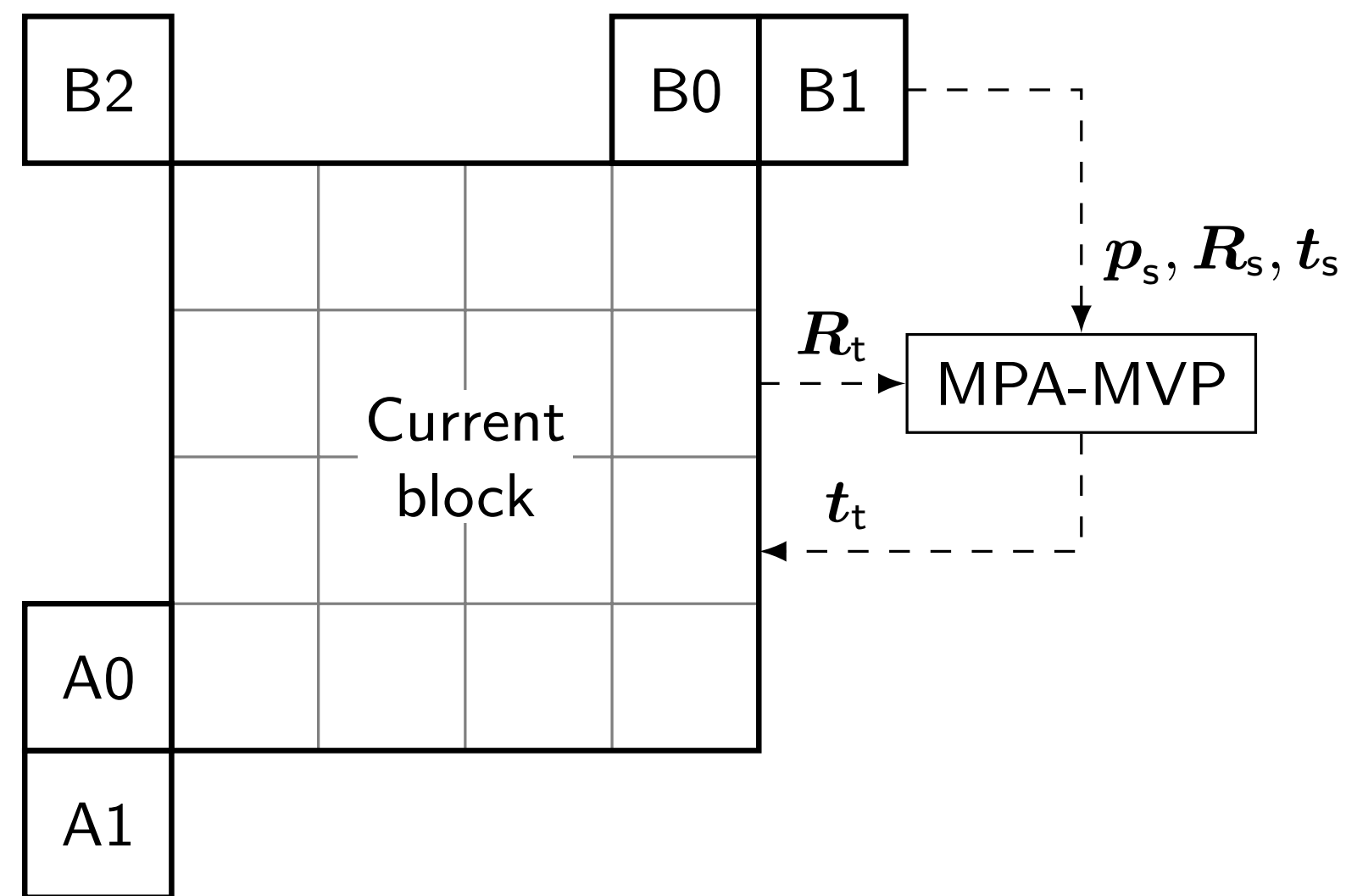

- MPA to MPA:

$$m_{\text{mpa}}(p_s, t_s, R_s) \stackrel{!}{=} m_{\text{mpa}}(p_s, t_t, R_t)$$

↓

$$t_t = \zeta_{R_t}(m_{\text{mpa}}(p_s, t_s, R_s)) - \zeta_{R_t}(p_s)$$

- Similar for MPA \leftrightarrow translational
- Also applicable to **affine MVP** and **merge candidate construction**

Li et al., "An Efficient Four-Parameter Affine Motion Model for Video Coding," IEEE Trans. Circuits Syst. Video Technol., vol. 28, no. 8, pp. 1934–1948, Aug. 2018.

Zhang et al., "An Improved Framework of Affine Motion Compensation in Video Coding," IEEE Trans. Image Process., vol. 28, no. 3, pp. 1456–1469, Mar. 2019.

Bross et al., "Versatile Video Coding (Draft 10), JVET-T2001-v2," in Proc. 20th Meeting of the Joint Video Exploration Team (JVET), 2020, pp. 1–521.

Outline

1. **Motion-Plane-Adaptive** Inter Prediction
 - a. Motion-Plane-Adaptive **Motion Model** (MPA)
 - b. Adapted **Motion Vector Prediction** (MPA-MVP)
2. Performance Evaluation
3. Conclusion

Experimental Setup

- **VTM-14.2** as baseline
- **Random access** configuration
- **32 frames of 10 grayscale sequences**
- **QPs 22, 27, 32, 37**
- Evaluation procedure according to **JVET 360-CTC**

ITU/ISO/IEC, "VVC VTM Reference Software VTM-14.2," 2021. [Online]. Available: https://vcgit.hhi.fraunhofer.de/jvet/VVCSoftware_VTM/-/tree/VTM-14.2.

Browne et al., "Algorithm Description for Versatile Video Coding and Test Model 14 (VTM 14), JVET-W2002-v1," in Proc. 23rd Meeting of the Joint Video Exploration Team (JVET), 2021, pp. 1–111.

Hanhart et al., "JVET Common Test Conditions and Evaluation Procedures for 360° Video, JVET-L1012," in Proc. 12th Meeting of the Joint Video Exploration Team (JVET), 2018, pp. 1–7.

Bossen et al., "VTM Common Test Conditions and Software Reference Configurations for SDR Video, JVET-T2010," in Proc. 20th Meeting of the Joint Video Experts Team (JVET), 2020, pp. 1–2.

G. Bjontegaard, "Calculation of Average PSNR Differences between RD-curves, VCEG-M33," in Proc. 13th Meeting Video Coding Experts Group, 2001, pp. 1–5.

Ye et al., "Algorithm Descriptions of Projection Format Conversion and Video Quality Metrics in 360Lib Version 12, JVET-T2004-v2," in Proc. 20th Meeting of the Joint Video Experts Team (JVET), 2020, pp. 1–65.

ITU/ISO/IEC, "360Lib Software 360Lib-12.0," 2020. [Online]. Available: https://jvet.hhi.fraunhofer.de/svn/svn_360Lib/tags/360Lib-12.0/.



Motion Model Comparison

BD-Rate in % for different motion models based on **WS-PSNR** with respect to VTM 14.2

	MPA	3DT	TAN	ROT	GED	TAN+ROT
SkateboardInLot	-1.06	+0.13	+0.78	+0.79	-0.13	+0.88
ChairliftRide	-1.22	-0.16	+0.10	+0.42	-1.19	+0.13
KiteFlite	+0.03	+0.08	+0.06	-0.02	+0.05	+0.29
Harbor	+0.27	+0.16	+0.31	+0.07	+0.13	+0.15
Trolley	+0.04	+0.16	-0.02	+0.23	+0.15	-0.04
GasLamp	-0.08	-0.10	-0.74	-0.47	-0.57	-0.64
Balboa	-1.87	-0.07	+0.59	+0.71	-0.53	+0.59
Broadway	-1.64	+0.11	+0.78	+0.50	-0.61	+0.52
Landing2	-2.92	-1.03	-1.72	+0.25	-3.50	-0.99
BranCastle2	-0.58	-0.22	+0.03	+0.18	-0.62	+0.15
Average	-0.90	-0.09	+0.02	+0.27	-0.68	+0.10

MPA-MVP=OFF

Li et al., "Projection Based Advanced Motion Model for Cubic Mapping for 360-Degree Video," in Proc. IEEE International Conference on Image Processing (ICIP), 2017, pp. 1427–1431.

Li et al., "Advanced Spherical Motion Model and Local Padding for 360° Video Compression," IEEE Trans. Image Process., vol. 28, no. 5, pp. 2342–2356, May 2019.

Wang et al., "A New Motion Model for Panoramic Video Coding," in Proc. IEEE International Conference on Image Processing (ICIP), 2017, pp. 1407–1411.

Wang et al., "Spherical Coordinates Transform-Based Motion Model for Panoramic Video Coding," IEEE J. Emerg. Sel. Top. Circuits Syst., vol. 9, no. 1, pp. 98–109, Mar. 2019.

De Simone et al., "Deformable Block-Based Motion Estimation in Omnidirectional Image Sequences," in Proc. IEEE 19th International Workshop on Multimedia Signal Processing (MMSP), 2017, pp. 1–6.

Vishwanath et al., "Rotational Motion Model for Temporal Prediction in 360 Video Coding," in Proc. IEEE 19th International Workshop on Multimedia Signal Processing (MMSP), 2017, pp. 1–6.

Vishwanath et al., "Rotational Motion Compensated Prediction in HEVC Based Omnidirectional Video Coding," in Proc. Picture Coding Symposium (PCS), 2018, pp. 323–327.

Vishwanath et al., "Motion Compensated Prediction for Translational Camera Motion in Spherical Video Coding," in Proc. IEEE 20th International Workshop on Multimedia Signal Processing (MMSP), 2018, pp. 1–4.

Marie et al., "Rate-Distortion Optimized Motion Estimation for on-the-Sphere Compression of 360 Videos," in Proc. IEEE International Conference on Acoustics, Speech and Signal Processing (ICASSP), 2021, pp. 1570–1574.

Rate-Distortion Analysis

BD-Rate for MPA in % with respect to VTM-14.2

MPA-MVP	PSNR		WS-PSNR		S-PSNR-NN		PSNR-DYN-VP0		PSNR-DYN-VP1	
	OFF	ON	OFF	ON	OFF	ON	OFF	ON	OFF	ON
SkateboardInLot	-0.97	-1.91	-1.06	-1.64	-1.02	-1.59	+0.14	-0.73	-0.15	-0.31
ChairliftRide	-1.56	-3.05	-1.22	-2.41	-1.27	-2.32	-0.58	-1.74	-1.54	-3.74
KiteFlite	-0.15	-0.03	+0.03	-0.02	+0.03	-0.05	+0.10	+0.04	+0.15	-0.33
Harbor	+2.80	+1.40	+0.27	-0.15	+0.17	-0.17	+0.01	-0.23	-0.11	-0.28
Trolley	+0.11	-0.38	+0.04	+0.01	+0.04	+0.01	+0.06	+0.20	+0.17	+0.24
GasLamp	+1.18	-1.27	-0.08	-0.43	-0.18	-0.46	+0.01	-0.12	-0.07	-0.47
Balboa	-2.05	-3.46	-1.87	-3.24	-1.84	-3.19	-1.79	-3.49	-2.65	-4.09
Broadway	-1.63	-3.12	-1.64	-3.11	-1.61	-3.09	-2.37	-3.95	-3.19	-5.40
Landing2	-3.37	-3.96	-2.92	-3.40	-2.89	-3.42	-3.07	-3.47	-4.01	-3.46
BranCastle2	-0.74	-1.42	-0.58	-1.19	-0.62	-1.19	-0.89	-1.11	-0.80	-1.28
Average	-0.64	-1.72	-0.90	-1.56	-0.92	-1.55	-0.84	-1.46	-1.22	-1.91

Inter Predicted Frames

Broadway, Frame 16, QP32



Original



VTM-14.2



MPA + MPA-MVP

Inter Predicted Frames

Landing2, Frame 4, QP32

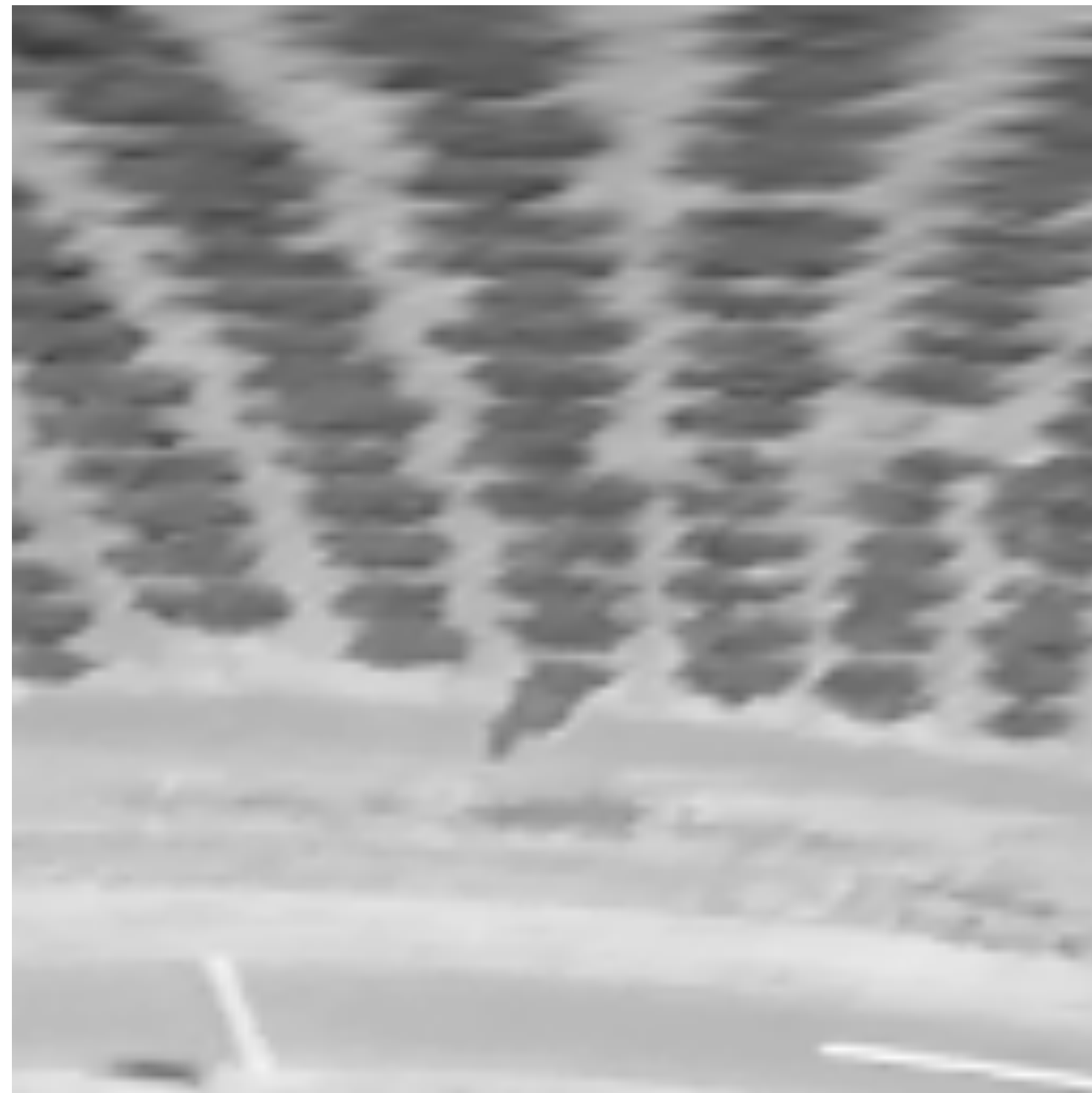

Original

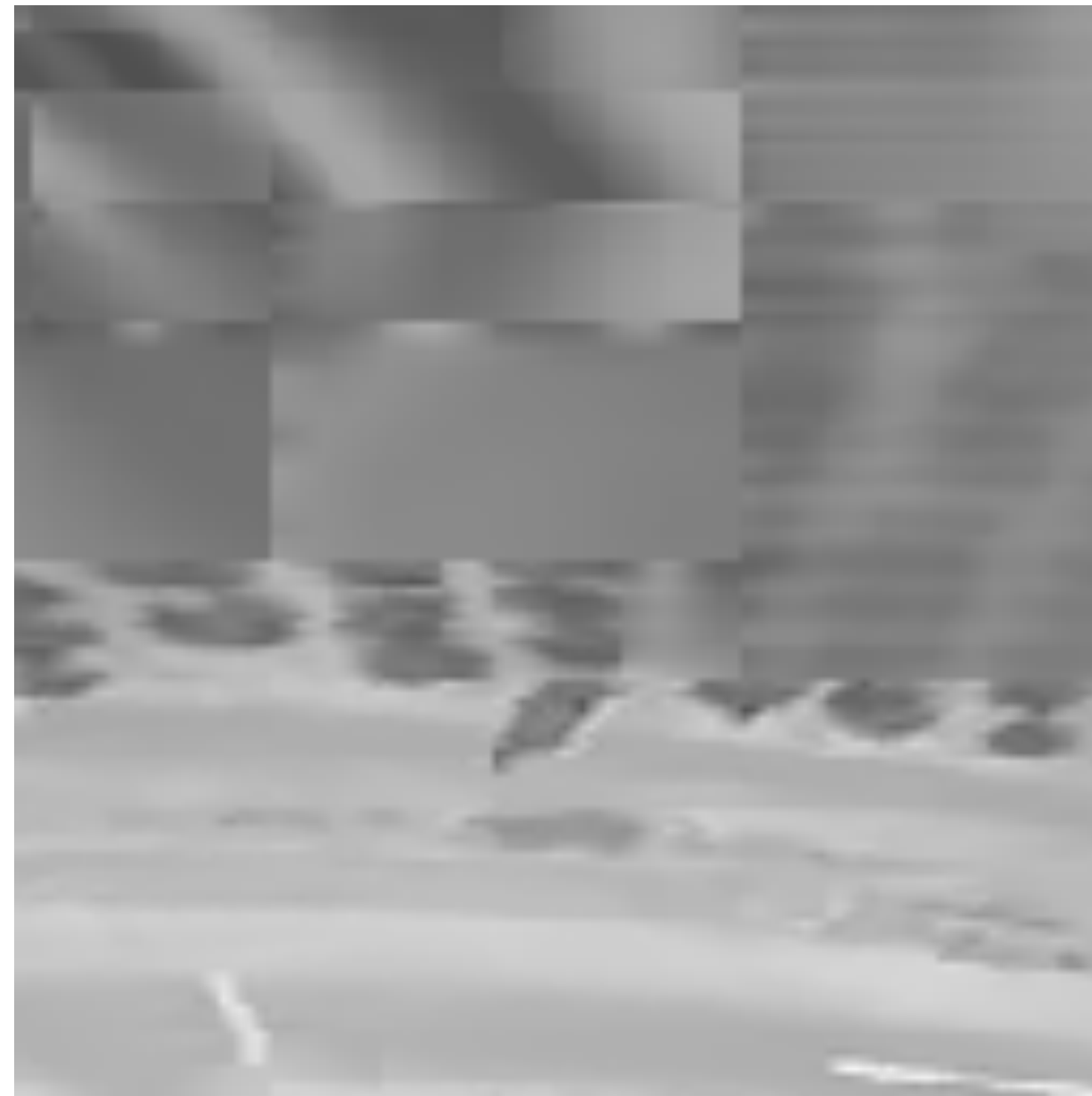

VTM-14.2

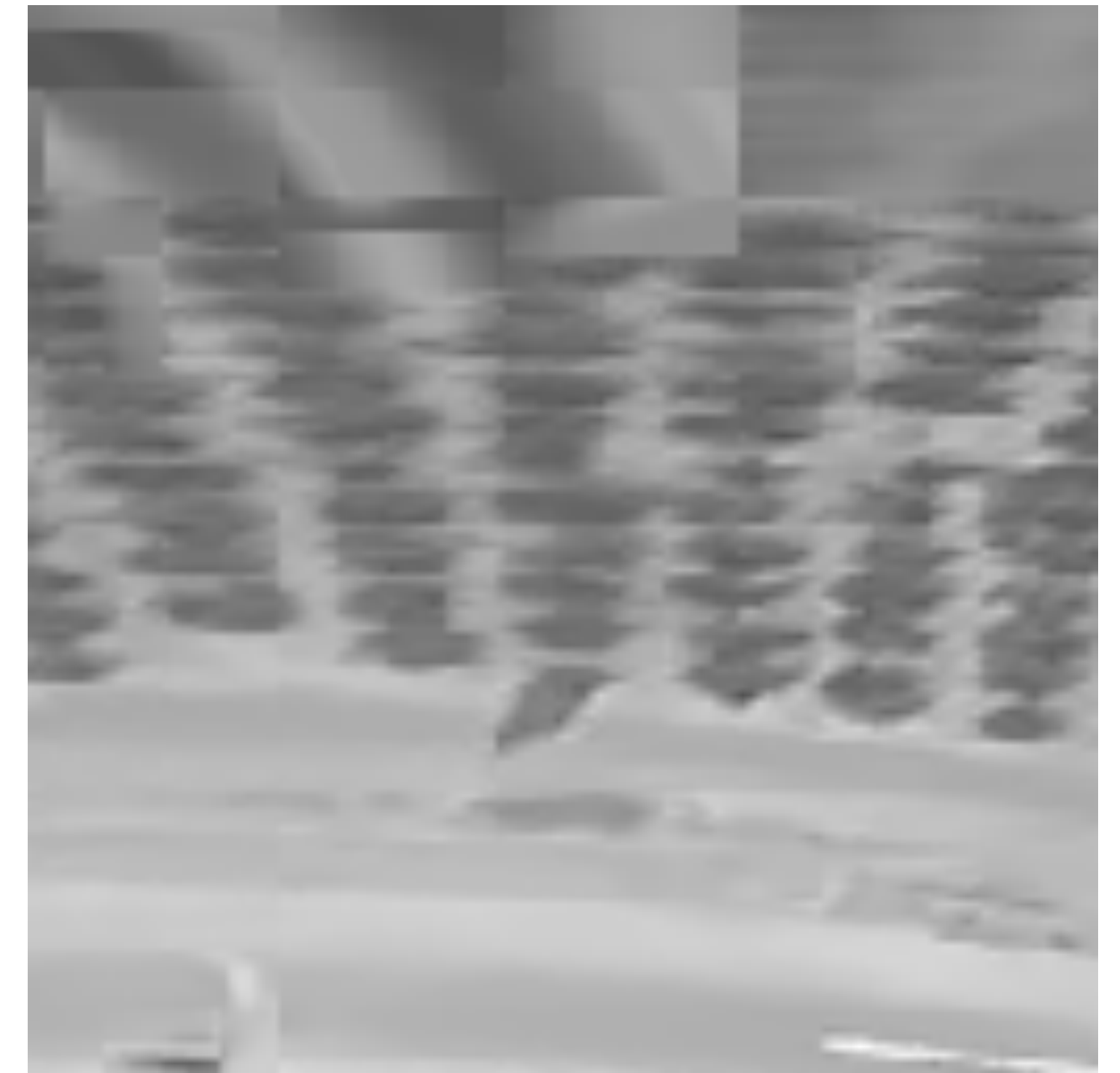

MPA + MPA-MVP

Outline

1. **Motion-Plane-Adaptive** Inter Prediction
 - a. Motion-Plane-Adaptive **Motion Model** (MPA)
 - b. Adapted **Motion Vector Prediction** (MPA-MVP)
2. Performance Evaluation
3. Conclusion

Conclusion

- MPA **among most competitive** 360-degree motion models
- MPA-MVP with additional rate savings of **more than 0.60%** on average
- Combined **rate savings of 1.56%** based on WS-PSNR on average

- Future work
 - Multi-model inter prediction
 - Affine MPA

Thank you!